

AERO CARE PREDICTOR

¹Tata Venkata Neeraj, ²Seeram Dileep, ³Yenumula Harishkumar, ⁴Tavva Venkata Sasi Pavan Kumar,

⁵Thota Amarnadh, ⁶K. Anusha

^{1,2,3,4,5}U. G Student, Dept ELECTRONICS AND COMMUNICATION ENGINEERING,

St. Ann's College of Engineering and Technology, (Autonomous)Chirala, Bapatla Dist,

Andhra Pradesh – 523187, India

⁶Assistant Professor, Dept ELECTRONICS AND COMMUNICATION ENGINEERING,

St. Ann's College of Engineering and Technology (Autonomous), Chirala, Bapatla Dist,

Andhra Pradesh – 523187, India

ABSTRACT

Aero Care Predictor is an IoT-based indoor air hazard monitoring system developed to improve environmental safety through continuous detection and monitoring of harmful gases and smoke in indoor environments. The system is designed to identify dangerous conditions such as smoke presence, combustible gas leakage, and carbon monoxide accumulation in real time, thereby reducing potential health and safety risks. It is suitable for applications in homes, laboratories, industries, and other enclosed spaces where air quality deterioration may create hazardous situations. The system utilizes a Raspberry Pi as the central controller responsible for collecting, processing, and analyzing sensor data. Multiple gas sensors are integrated into the system, including the MQ-2 sensor for smoke and flammable gas detection, MQ-5 for LPG and natural gas sensing, and MQ-7 for carbon

monoxide monitoring. These sensors continuously monitor air quality parameters and transmit real-time readings to the Raspberry Pi for analysis. A buzzer is used to generate immediate audible alerts whenever hazardous gas concentrations exceed predefined threshold values. The IoT communication module enables wireless transmission of sensor readings and alerts to cloud servers for remote monitoring and data storage. The system classifies air quality conditions into Safe, Warning, and Danger levels, enabling users to take preventive actions.

KEYWORDS: *IoT-based Air Monitoring, Embedded Systems, Raspberry Pi, Gas and Smoke Detection*

INTRODUCTION

Indoor air quality has become an important concern in modern environments due to increasing urbanization and the use of gas-

based appliances in homes, laboratories, and industries. Harmful gases such as carbon monoxide, LPG, methane, and smoke can accumulate in enclosed spaces and create serious health and safety risks. Traditional monitoring systems often provide limited functionality and lack real-time analysis and remote accessibility. Aero Care Predictor is an IoT-based indoor air hazard monitoring system developed using Raspberry Pi and MQ-series sensors for detecting hazardous gases and smoke. The system provides real-time monitoring, cloud connectivity, and intelligent hazard classification for improving environmental safety and early risk detection.

RELATED WORK

Several researchers have developed IoT-based air quality monitoring systems for detecting harmful gases and improving environmental safety. Existing systems commonly use gas sensors, microcontrollers, and wireless communication modules to monitor pollutants and provide real-time alerts. Studies involving MQ-series sensors and Raspberry Pi platforms have shown effective detection of smoke, LPG leakage, and carbon monoxide levels in indoor environments.

Cloud-based monitoring systems further enable remote access and data visualization

through web dashboards. Some advanced approaches integrate machine learning techniques for predictive analysis and intelligent decision-making.

LITERATURE REVIEW

Recent research on indoor air quality monitoring systems has focused on detecting harmful gases and improving environmental safety through embedded systems and IoT technologies. Earlier methods relied on manual monitoring and laboratory analysis, which were costly and lacked real-time capabilities. Sensor-based systems using MQ-series gas sensors improved gas detection and local alert mechanisms. IoT integration further enhanced monitoring by enabling real-time data transmission, cloud storage, and remote access. Recent studies also introduced machine learning techniques for intelligent air quality classification and prediction. However, challenges such as implementation complexity, high cost, and network dependency still exist in many systems.

EXISTING METHOD

The existing air quality monitoring systems mainly rely on manual monitoring, conventional alarm systems, and standalone microcontroller-based solutions for detecting harmful gases and smoke.

These systems use gas sensors to monitor air conditions and activate alarms when gas concentration exceeds predefined threshold values. Some systems provide local displays and basic monitoring capabilities, while IoT-based systems support remote data visualization.

However, they lack intelligent analysis, predictive capability, and real-time decision-making. Limitations such as false alarms, absence of historical data analysis, no hazard prediction, and limited scalability reduce their effectiveness in ensuring complete indoor environmental safety.

PROPOSED METHOD

The proposed Aero Care Predictor is an IoT-based indoor air hazard monitoring system designed for real-time detection and prediction of harmful gases and smoke. The system uses MQ-2, MQ-5, and MQ-7 sensors with a Raspberry Pi for continuous monitoring and processing of air quality data. Sensor readings are analyzed using predefined thresholds and machine learning techniques to classify air conditions into Safe, Warning, and Danger levels.

When hazardous conditions are detected, a buzzer generates alerts and data is transmitted to the cloud for remote monitoring. The system provides intelligent, scalable, and reliable environmental safety management.

SYSTEM ARCHITECTURE

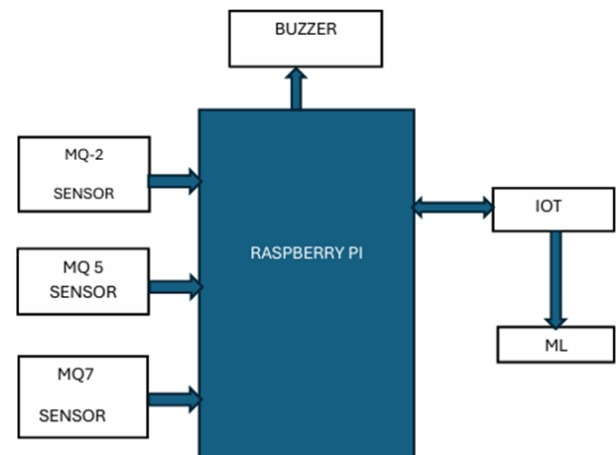

Fig 1: Block Diagram

METHODOLOGY DESCRIPTION

Gas Sensing Unit

The MQ-2 sensor is used to detect smoke and flammable gases present in the indoor environment. It continuously monitors air quality and sends sensor values to the Raspberry Pi for further processing.

LPG and Gas Detection Unit

The MQ-5 sensor is responsible for detecting LPG, natural gas, and combustible gas leakage. It provides real-time sensing information to identify hazardous gas concentrations.

Carbon Monoxide Monitoring Unit

The MQ-7 sensor detects carbon monoxide levels in the surrounding environment. It helps in identifying toxic gas accumulation and improves overall indoor safety.

Processing and Alert Unit

The Raspberry Pi acts as the central controller that receives and processes data from all connected sensors. Based on predefined conditions, it activates the buzzer to provide immediate alerts during hazardous situations.

IoT and Intelligent Analysis Unit

The IoT platform transfers sensor readings to cloud servers for remote monitoring and data storage. Machine learning techniques analyze collected data and classify air quality conditions for predictive hazard detection.

SOFTWARE AND HARDWARE REQUIREMENTS

Hardware Requirements

Raspberry Pi



Fig 2: Raspberry

Raspberry Pi acts as the main processing and control unit of the Aero Care Predictor system. It receives sensor data, processes information, and controls alert generation and cloud communication.

MQ-2 Sensor



Fig 3: MQ-2 Sensor

The MQ-2 sensor is used to detect smoke and flammable gases in the environment. It continuously monitors air conditions and provides real-time sensing information.

MQ-5 Sensor



Fig 4: MQ-5 Sensor

The MQ-5 sensor detects LPG, natural gas, and combustible gas leakage. It helps in identifying hazardous gas concentrations and preventing dangerous situations.

MQ-7 Sensor



Fig 5: MQ-7 Sensor

The MQ-7 sensor is used to detect carbon monoxide gas present in indoor environments. It provides accurate monitoring of toxic gas levels to improve safety.

Buzzer



Fig 6: Buzzer

The buzzer is used as an audible alert mechanism during hazardous conditions. It immediately warns users when gas concentration exceeds safe limits.

IoT Communication Module

The IoT communication module enables wireless transmission of sensor data to cloud platforms. It supports remote monitoring and real-time notifications for users.

Software Requirements

Python Programming Environment and IoT Platform

Python software is used to develop algorithms for sensor data acquisition, processing, and hazard classification in the Aero Care Predictor system. The software continuously reads sensor values, compares them with predefined thresholds, and controls alert mechanisms accordingly. It also enables IoT communication, cloud data storage, machine learning integration, and real-time monitoring through web dashboards.

RESULTS AND DISCUSSION

The Aero Care Predictor system was developed and successfully implemented to monitor air quality in real time, calculate the Air Quality Index (AQI), perform air quality labeling, and predict potential health risks using machine learning techniques. The system makes use of MQ-2, MQ-5, and MQ-7 sensors to detect the presence of harmful gases such as smoke, liquefied petroleum gas (LPG), methane, and carbon monoxide in the surrounding environment. These sensors continuously collect data, which is then processed to determine the concentration levels of pollutants present in the air. The collected sensor values are further analyzed to compute the AQI, which provides a standardized numerical representation of

air pollution levels. Based on the calculated AQI values, the system categorizes air quality into different levels such as Good, Moderate, Unhealthy, Very Unhealthy, and Hazardous, enabling users to easily understand the environmental conditions without interpreting complex data.

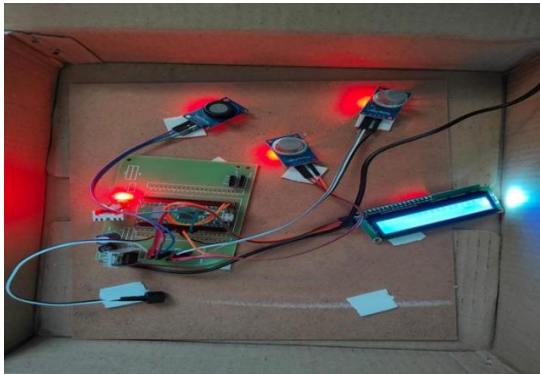

Fig 7: results process kit

In addition to AQI calculation, the system integrates a machine learning model that analyzes the patterns in sensor data and predicts possible diseases that may arise due to prolonged exposure to polluted air. These predicted health risks include respiratory disorders such as asthma, chronic bronchitis, and other pollution-related conditions. The machine learning model was trained using relevant datasets, allowing it to identify correlations between pollutant levels and health impacts with reasonable accuracy. The results obtained from the system demonstrate that it is capable of providing continuous monitoring and real-time feedback, which is essential for early detection of hazardous

conditions. The AQI values generated were found to be consistent with expected pollution the condition worsens. However, the system's performance may be influenced by factors such as sensor calibration, environmental conditions like temperature and humidity, and the quality of training data used in the machine learning model.

Despite these minor limitations, the Aero Care Predictor proves to be an efficient, cost-effective, and practical solution for monitoring air quality, predicting health risks, and promoting awareness about environmental safety. The integration of IoT-based sensing with intelligent data analysis makes this system highly suitable for applications in smart homes, workplaces, and urban environments, where maintaining air quality is crucial for ensuring human health and well-being.

CONCLUSION

The Aero Care Predictor was successfully developed as an intelligent IoT-based indoor air hazard monitoring system for improving environmental safety. The system continuously monitors harmful gases and smoke using multiple sensors and provides real-time alerts during hazardous conditions. It offers a reliable, cost-effective, and scalable solution for

protecting human health and ensuring safer indoor environments.

FUTURE SCOPE

The system can be enhanced by integrating advanced Artificial Intelligence and Machine Learning techniques for accurate hazard prediction and intelligent decision-making. Additional sensors, mobile applications, and smart automation features can be incorporated to improve monitoring and response capabilities. Future developments can transform the system into a fully automated and highly efficient environmental safety platform.

REFERENCES

1. Hanwei Electronics Co., Ltd., “MQ-2 Semiconductor Sensor for Combustible Gas – Technical Data,” Winsen Sensor Technology Co., Ltd., 2019.
2. Pololu Corporation, “MQ-2 Semiconductor Sensor for Combustible Gas Datasheet,” Pololu Electronics, 2020.
3. Hanwei Electronics Co., Ltd., “MQ-5 Semiconductor Sensor for Flammable Gas – Technical Data,” Winsen Sensor Technology Co., Ltd., 2019.
4. Seeed Studio, “Grove MQ-5 Gas Sensor User Manual,” Seeed Technology Inc., 2020.
5. SparkFun Electronics, “MQ-7 Carbon Monoxide Gas Sensor Datasheet,” SparkFun Electronics, 2021.
6. Hanwei Electronics Co., Ltd., “MQ-7 Gas Sensor Technical Data Sheet,” Hanwei Sensor Series, 2020.
7. Raspberry Pi Foundation, “Raspberry Pi Documentation and Technical Specifications,” Raspberry Pi Foundation, 2021.
8. Raspberry Pi Foundation, “Raspberry Pi 3 Model B Product Specifications,” Raspberry Pi Foundation, 2020.
9. RS Components, “Raspberry Pi 3 Model B Technical Specification,” RS Online, 2021.
10. OASIS Standard, “MQTT Version 3.1.1 Protocol Specification,” OASIS Open, 2014.
11. HiveMQ Team, “MQTT Essentials: Introducing MQTT Protocol,” HiveMQ Blog, 2020.
12. World Health Organization (WHO), “WHO Guidelines for Indoor Air Quality: Selected Pollutants,” WHO Publications, 2010.
13. D. Penney et al., “Carbon Monoxide Exposure and Indoor Air Quality,” WHO Indoor Air Quality Review, 2010.
14. Dey, “Semiconductor Metal Oxide Gas Sensors: A Review,” Sensors and Actuators B: Chemical, vol. 229, pp. 206–217, 2016.

15. T. Dutta et al., “Road Map of Semiconductor Metal-Oxide-Based Gas Sensors,” *Sensors*, vol. 22, no. 5, pp. 1–20, 2022.
16. M. Karmoude et al., “Machine Learning for Air Quality Prediction and Data Analysis: A Review,” *ScienceDirect*, 2025.
17. Y. C. Liang et al., “Machine Learning-Based Prediction of Air Quality,” *Applied Sciences*, vol. 10, no. 24, pp. 1–15, 2020.
18. P. Chaturvedi et al., “Air Quality Prediction System Using Machine Learning Models,” *Water, Air and Soil Pollution*, Springer, 2024.
19. Scikit-learn Developers, “Scikit-learn: Machine Learning in Python Documentation,” Scikit-learn Organization, 2023.
20. S. Madakam, R. Ramaswamy, and S. Tripathi, “Internet of Things (IoT): A Literature Review,” *Journal of Computer and Communications*, vol. 3, no. 5, pp. 164–173, 2015.