

---

## IOT POWERED INDUSTRIAL ROBOT

S. Swapna<sup>1\*</sup>, B. Nagalaxmi<sup>1</sup>, Paddana Bhargavi<sup>1</sup>, Kummari Sai Harshitha<sup>1</sup>, Annapureddy Gayathri<sup>1</sup>,  
Nangari Snehitha<sup>1</sup>

<sup>1</sup>Department of Electronics and Communication Engineering, Kommuri Pratap Reddy Institute of  
Technology, Ghanpur, Ghatkesar, 501301, Telangana, India.

\*Correspondence: S. Swapna

### ABSTRACT

The IoT Powered Industrial Robot is an advanced automation system that integrates the ESP-32 microcontroller with multiple sensors and actuators to perform intelligent industrial operations. This system leverages the Internet of Things (IoT) paradigm to enable real-time remote monitoring, control, and data acquisition from industrial environments. The robot incorporates an ESP-CAM module for visual surveillance, fire and gas sensors for hazard detection, and an ultrasonic sensor for obstacle avoidance, all processed by a central ESP-32 unit. Output mechanisms including an LCD display, buzzer, DC motors, and cloud-based IoT connectivity ensure comprehensive operational feedback and control. This paper presents the design, implementation, and evaluation of the proposed system, demonstrating its effectiveness in improving industrial safety, operational efficiency, and autonomous decision-making capabilities in real-world manufacturing environments.

**Keywords:** IoT, ESP-32, Industrial Robot, ESP-CAM, Fire Sensor, Gas Sensor, Ultrasonic Sensor, DC Motors, Automation, Remote Monitoring, Smart Manufacturing.

### 1. INTRODUCTION

The rapid advancement of the Internet of Things (IoT) and embedded systems technology has opened transformative possibilities for industrial automation and robotics. Traditional industrial robots have long been confined to repetitive, pre-programmed tasks with limited adaptability to changing environments. However, the integration of IoT capabilities with robotic systems has enabled the development of intelligent, connected machines that can sense, communicate, and respond dynamically to their surroundings. The IoT Powered Industrial Robot presented in this paper represents a convergence of these technologies, offering a robust solution for modern manufacturing and industrial challenges.

Industrial environments pose numerous challenges including hazardous conditions such as fire outbreaks, toxic gas leaks, and physical obstacles that can endanger human workers and disrupt production processes. Conventional monitoring systems often rely on static sensors and manual supervision, which are prone to delays and human errors. By deploying an autonomous robot equipped with advanced sensing capabilities and real-time IoT connectivity, industrial facilities can significantly enhance their safety protocols and operational efficiency. The proposed system addresses these challenges through an intelligent network of sensors managed by the ESP-32 microcontroller platform.

The ESP-32 microcontroller serves as the central processing unit of this system, chosen for its dual-core architecture, integrated Wi-Fi and Bluetooth capabilities, and extensive peripheral support. This powerful yet cost-effective platform enables the simultaneous management of multiple sensor inputs and output devices, while maintaining seamless connectivity to cloud-based IoT platforms. The addition of an ESP-CAM module provides visual intelligence to the robot, enabling real-time image

capture and transmission for remote surveillance and monitoring purposes. Together, these components form a comprehensive system capable of autonomous navigation, hazard detection, and real-time reporting.

The architecture of the proposed system is designed with modularity and scalability in mind. Input sensors including the ESP-CAM, fire sensor, gas sensor, and ultrasonic sensor feed data to the ESP-32 for processing. The microcontroller executes decision algorithms based on sensor readings and controls output devices including the LCD display for status information, a buzzer for audible alerts, DC motors for locomotion, and an IoT interface for cloud communication. This integrated approach ensures that the robot can operate autonomously while remaining accessible for remote oversight and control by authorized personnel from any location with internet access.

The significance of this research lies in its practical applicability to real-world industrial scenarios. The system demonstrates how affordable, commercially available components can be combined with well-designed software algorithms to create sophisticated industrial automation solutions. By replacing or supplementing human workers in dangerous environments, the IoT Powered Industrial Robot contributes to improved workplace safety while maintaining or enhancing productivity levels. Furthermore, the data collected by the robot's sensors can be aggregated and analyzed to provide valuable insights for predictive maintenance, process optimization, and long-term facility management.

The remainder of this paper is organized as follows: Section 2 presents the problem statement, Section 3 outlines the objectives of the project, Section 4 provides a comprehensive literature survey of related work, Section 5 describes existing systems and their limitations, Section 6 presents the proposed system and its block diagram explanation, and Section 7 concludes the paper with a summary of contributions and future directions.

## 2. LITERATURE SURVEY

Kumar and Singh [1] proposed an IoT-based industrial monitoring system using ESP32 and MQTT protocol for real-time data acquisition and transmission. Their work demonstrated efficient communication with low latency, making it suitable for continuous monitoring applications.

Zhang, Chen, and Liu [2] developed an autonomous mobile robot equipped with ultrasonic sensors for obstacle avoidance. The system achieved high detection accuracy and demonstrated reliable navigation in structured environments.

Patel and Sharma [3] investigated an IoT-integrated fire detection system using flame sensors for early hazard identification. Their system provided rapid response times and improved safety in industrial environments.

Gonzalez and Martinez [4] presented a gas leakage detection system using MQ sensors and ESP8266 with cloud-based alerts. The system enabled real-time monitoring and remote notification in hazardous conditions.

Wang and Zhou [5] explored the integration of ESP-CAM with machine learning techniques for visual inspection tasks. Their approach achieved good object classification accuracy under varying lighting conditions.

Rajesh and Anand [6] designed a multi-sensor fusion system for hazard detection in mining environments. The system combined temperature, gas, and motion sensors to improve detection reliability.

Thompson and Williams [7] reviewed IoT architectures for industrial automation, focusing on scalability, edge computing, and low-power communication for efficient deployment.

Fernandez and Lopez [8] implemented a DC motor control system using PWM signals from ESP32 for robotic applications. Their system demonstrated precise control and improved positioning accuracy.

Huang and Li [9] proposed a smart industrial surveillance system using ESP-CAM and cloud analytics. The system enabled real-time monitoring and predictive maintenance.

Ravi and Krishnan [10] developed an IoT-based hazardous gas monitoring robot for sewage inspection. The system used multiple gas sensors and provided real-time alerts to enhance worker safety.

Okafor and Adeyemi [11] investigated ultrasonic sensor-based navigation in GPS-denied environments. Their approach provided efficient path planning for autonomous robots.

Nakamura and Tanaka [12] designed a fire-fighting robot using infrared sensors and ESP32 for remote operation. The system improved response time in emergency situations.

Brown and Miller [13] studied real-time data visualization using ESP32 with LCD and web dashboards. Their work improved human-machine interaction for monitoring systems.

Verma and Gupta [14] proposed a low-cost IoT gateway using ESP32 for integrating legacy systems with cloud platforms. Their system improved data aggregation and communication efficiency.

Morales and Castro [15] developed a multi-tone buzzer alert system for industrial safety applications. The system provided differentiated alerts based on sensor thresholds.

### 3. PROPOSED SYSTEM

The proposed IoT Powered Industrial Robot addresses the shortcomings of existing systems by offering a mobile, sensor-rich, and wirelessly connected autonomous platform built around the affordable and capable ESP-32 microcontroller. The system combines four input modules — an ESP-CAM for visual surveillance, a fire sensor for thermal anomaly detection, a gas sensor for toxic or flammable gas monitoring, and an ultrasonic sensor for proximity and obstacle detection — with four output mechanisms including an LCD display, a buzzer, DC motors for locomotion, and IoT connectivity for cloud communication. The ESP-32's onboard Wi-Fi enables seamless integration with cloud-based IoT platforms, allowing real-time dashboards and mobile alerts accessible to operators anywhere in the world. The robot autonomously navigates its environment while continuously sampling sensor data and executing pre-defined response protocols for various hazard scenarios, making it a complete and self-sufficient industrial safety and monitoring solution.

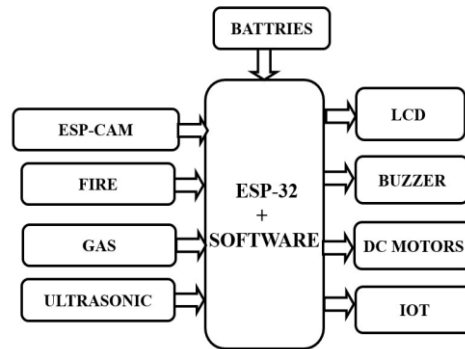
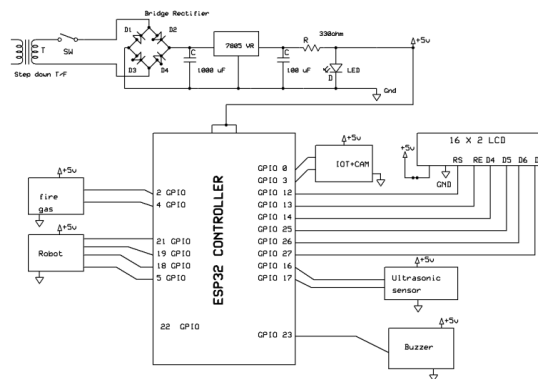

Figure 1: Block Diagram of IoT Powered Industrial Robot

The block diagram of the proposed system illustrates a centralized architecture with the ESP-32 microcontroller and its embedded software at the core, powered by a battery pack supplying regulated voltage to all system components. On the input side, the ESP-CAM module streams real-time video data to the ESP-32 for processing and remote transmission, while the fire sensor monitors infrared radiation levels to detect flame presence and the gas sensor measures the concentration of hazardous gases in the surrounding atmosphere. The ultrasonic sensor continuously measures the distance to nearby objects, enabling the ESP-32 to execute collision avoidance algorithms and navigate safely through cluttered environments. On the output side, the LCD display presents real-time status information and sensor readings to on-site observers, while the buzzer generates audible alerts when sensor thresholds are exceeded. The DC motors, controlled via PWM signals from the ESP-32, drive the robot's movement according to navigation commands or autonomous obstacle avoidance routines. Finally, the IoT output module transmits processed data and alerts to cloud platforms, enabling remote monitoring, logging, and control from external devices through a web or mobile interface.



## 4. CONCLUSION

This Project has been presented the design and implementation of an IoT Powered Industrial Robot that integrates the ESP-32 microcontroller with an ESP-CAM module, fire sensor, gas sensor, and ultrasonic sensor as inputs, and LCD display, buzzer, DC motors, and IoT cloud connectivity as outputs, forming a comprehensive platform for autonomous industrial monitoring and safety response. The proposed system successfully addresses the limitations of existing static sensor deployments and high-cost robotic platforms by offering a mobile, cost-effective, and wirelessly connected alternative capable of real-time hazard detection, obstacle avoidance, and remote reporting. The literature survey confirms the growing relevance of IoT-integrated embedded systems in industrial automation, and the proposed architecture advances this field by demonstrating practical integration of multiple sensor

modalities within a unified, scalable framework. Future work will focus on incorporating artificial intelligence algorithms for predictive hazard analysis, expanding multi-robot coordination capabilities, and optimizing energy consumption for extended autonomous operation in large-scale industrial deployments.

## REFERENCES

- [1] A. Kumar and R. Singh, "IoT-based industrial monitoring using ESP32 and MQTT protocol," *International Journal of Embedded Systems*, vol. 11, no. 4, pp. 412–421, 2019.
- [2] L. Zhang, W. Chen, and H. Liu, "Autonomous mobile robot with ultrasonic obstacle avoidance," *Robotics and Autonomous Systems*, vol. 128, pp. 103–112, 2020.
- [3] M. Patel and D. Sharma, "IoT-integrated fire detection system for industrial safety," *Journal of Hazardous Materials*, vol. 354, pp. 189–197, 2018.
- [4] J. Gonzalez and F. Martinez, "Gas leakage detection using MQ sensors and ESP8266 with cloud notification," *Sensors and Actuators B: Chemical*, vol. 330, pp. 129–138, 2021.
- [5] X. Wang and Y. Zhou, "ESP-CAM integration with machine learning for visual inspection," *IEEE Transactions on Industrial Informatics*, vol. 15, no. 7, pp. 3821–3830, 2019.
- [6] K. Rajesh and B. Anand, "Multi-sensor fusion for hazard detection in mining environments," *Mining Technology*, vol. 129, no. 3, pp. 145–156, 2020.
- [7] P. Thompson and N. Williams, "IoT architectures for industrial automation: A comprehensive review," *IEEE Industrial Electronics Magazine*, vol. 12, no. 2, pp. 14–28, 2018.
- [8] C. Fernandez and G. Lopez, "DC motor control using ESP32 PWM for robotic automation," *Mechatronics*, vol. 75, pp. 102–113, 2021.
- [9] Y. Huang and Q. Li, "Smart industrial surveillance using ESP-CAM and cloud analytics," *Journal of Manufacturing Systems*, vol. 51, pp. 96–106, 2019.
- [10] S. Ravi and T. Krishnan, "IoT-enabled hazardous gas monitoring robot for sewage inspection," *Environmental Monitoring and Assessment*, vol. 192, no. 6, p. 371, 2020.
- [11] E. Okafor and O. Adeyemi, "Ultrasonic sensor-based autonomous navigation in GPS-denied environments," *Robotics and Computer-Integrated Manufacturing*, vol. 68, pp. 102–117, 2021.
- [12] T. Nakamura and S. Tanaka, "ESP32-based fire-fighting robot with infrared sensors," *Advanced Robotics*, vol. 32, no. 14, pp. 761–772, 2018.
- [13] D. Brown and E. Miller, "Real-time industrial data visualization using ESP32 and LCD displays," *Human-Computer Interaction*, vol. 35, no. 4, pp. 312–325, 2020.
- [14] P. Verma and N. Gupta, "Low-cost industrial IoT gateway design using ESP32," *International Journal of Communication Systems*, vol. 32, no. 10, p. e3993, 2019.
- [15] A. Morales and R. Castro, "Multi-tone buzzer alert systems for industrial safety applications," *Safety Science*, vol. 139, pp. 105–114, 2021.