

NOVEL INVERTER ARCHITECTURE FOR THIRD HARMONIC ELIMINATION

¹K BHAJARANG

Dept. Of Electrical and Electronics Engineering

Narsimha reddy engineering college

Maisammaguda, Kompally, Secunderabad, Hyderabad, Telangana 500100

Email: 21X05A0209@nrcmec.org

²TEKU KIRAN KUMAR

Dept. Of Electrical and Electronics engineering

Narsimha reddy engineering college

Maisammaguda, Kompally, Secunderabad, Hyderabad, Telangana 500100

Email: 21X05A0219@nrcmec.org

³C MALLESH

Dept. Of Electrical and Electronics Engineering

Narsimha reddy engineering college

Maisammaguda, Kompally, Secunderabad, Hyderabad, Telangana 500100

Email: 21X05A0223@nrcmec.org

⁴MAMIDI PRASHANTH KUMAR GOUD

Dept. Of Electrical and Electronics ENgineering

Narsimha reddy engineering college

Maisammaguda, Kompally, Secunderabad, Hyderabad, Telangana 500100

Email: 21X05A0237@nrcmec.org

⁵DR. A.IMMANUEL

Dept. Of Electrical and Electronics Engineering

Narsimha reddy engineering college

Maisammaguda, Kompally, Secunderabad, Hyderabad, Telangana 500100

Email: anupalliimmanuel@gmail.com

Received: 02-03-2024

Accepted: 08-04-2024

Published: 15-04-2024

Abstract— *The proposed work focuses on implementing a third harmonic elimination technique in an inverter system using the SG3525 PWM controller along with an optocoupler. The primary objective is to minimize harmonic distortion in the output voltage waveform, thereby improving efficiency and reducing stress on the connected loads. The SG3525 generates the required pulse-width modulated (PWM) signals, while the optocoupler provides galvanic isolation between the control circuit and the power stage for safe and reliable operation. By applying suitable modulation strategies and control algorithms, the third harmonic component is effectively suppressed, producing a cleaner sinusoidal output. The project details the design methodology, simulation studies, and experimental validation, clearly demonstrating the effectiveness of the approach in harmonic mitigation and enhancing the overall performance of the inverter system.*

Keywords— *inverter; Pulse Width Modulation; harmonic; controller.*

I. INTRODUCTION

In the field of power electronics, inverters are essential for converting DC power into AC power across applications such as renewable energy systems, uninterruptible power supplies (UPS), and motor drives. Despite their widespread use, conventional inverters are prone to introducing harmonic distortions into the output voltage waveform, resulting in efficiency losses and potential adverse effects on connected loads [11][12][13][14].

To mitigate this issue, the concept of a Third Harmonic Less Inverter is introduced, with a focus on suppressing the third harmonic component of the output waveform. This is particularly significant, as the third harmonic can cause resonance problems and interfere with the operation of sensitive equipment in power systems.

The SG3525 PWM (Pulse Width Modulation)

controller forms the core of this project, enabling accurate regulation of the inverter's switching transistors. Through its advanced modulation capabilities, the controller facilitates efficient voltage regulation while minimizing waveform distortion. To further enhance operational safety and reliability, optocouplers are integrated to provide galvanic isolation between the control and power circuits. This isolation prevents issues arising from voltage surges, ground loops, and electrical noise, ensuring stable and secure system performance.

By combining advanced control strategies with innovative circuit design, the proposed Third Harmonic Less Inverter aims to deliver a cleaner and more efficient AC output, making it highly suitable for diverse applications that demand high-quality power.

II. METHODOLOGY

Block diagram of proposed Third Harmonic Less Inverter is shown in figure 1.

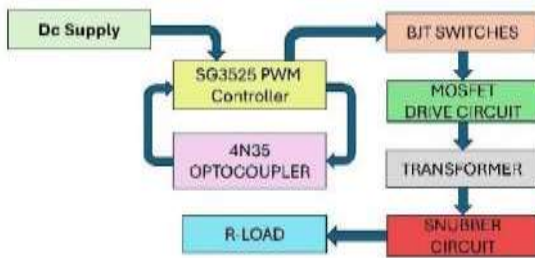

Fig.1. Block diagram of Third Harmonic Less Inverter.

1. SG3525 PWM Controller

The SG3525 is a pulse width modulator (PWM) controller commonly used in power electronics applications such as inverters. In a third harmonic less inverter, the SG3525 is utilized to control the generation of the PWM signals that drive the inverter's switching devices, typically MOSFETs.[1]

The SG3525 generates PWM signals with variable duty cycle based on the input voltage and reference voltage. This allows precise control of the output waveform.

The design of the PWM signals generated by the SG3525, combined with appropriate filtering and modulation techniques, aims to reduce the generation of third harmonic components in the output waveform. This is typically achieved by carefully selecting the modulation index and shaping the PWM signals to minimize third harmonic distortion, resulting in a cleaner output waveform with reduced harmonic content.[4]

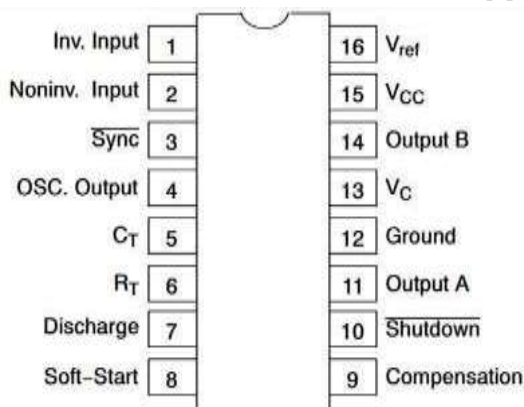

Fig.2. SG3525 pin layout

2. 4N35 Optocoupler

The 4N35 Optocoupler serves a critical role in the third harmonic less inverter system when paired with the SG3525 PWM controller.

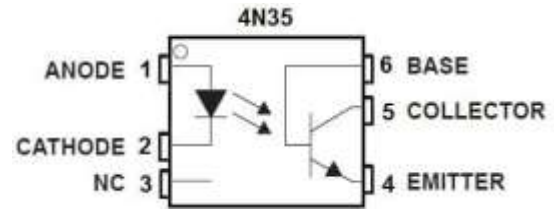

Fig.3. 4N35 Optocoupler pin layout

The 4N35 optocoupler provides electrical isolation between the control circuitry (where the SG3525 is located) and the power circuitry (which includes the inverter's high voltage components). This isolation ensures safety by preventing direct electrical contact between these two sections, which could otherwise lead to hazards like electric shocks or damage to sensitive components.[3]

By isolating the control and power circuits, the 4N35 helps prevent noise and interference from affecting the operation of the SG3525 and other control components. This is crucial for maintaining stable and accurate control signals, especially in high-power applications like inverters where noise can easily disrupt operation.

Despite providing isolation, the 4N35 allows for the transmission of control signals from the SG3525 to the power circuitry. This enables the SG3525 to adjust the PWM signals based on feedback or control algorithms, ensuring precise control over the inverter's output waveform.

In addition to isolation, the optocoupler also offers a level of protection against voltage spikes and transients. It helps prevent damage to the SG3525 and other control components by limiting the transmission of excessive voltage or current fluctuations from the power circuitry.

3. BJT

BJTs can serve as the switching devices responsible for converting the DC input into an AC output. They alternate between ON and OFF states according to the PWM signals generated by the SG3525. When ON, they allow current to flow through the load, and when OFF, they block current flow. By controlling the timing and duration of these states via the PWM signals, the SG3525 regulates the output voltage and frequency.

By having one transistor in cutoff and the other in saturation, the inverter can achieve efficient switching with minimal switching losses. When one transistor is in cutoff, it effectively interrupts the current flow, reducing power dissipation. Meanwhile, the transistor

in saturation allows for maximum current flow during that phase, enhancing efficiency.

Cross-conduction, where both transistors conduct simultaneously, can lead to short circuits and high-power dissipation. By ensuring that one transistor is always in cutoff while the other is in saturation, the risk of cross-conduction is minimized, improving overall reliability and efficiency.

4. Power MOSFET

MOSFETs act as the main switching devices in the inverter circuit. They control the flow of current through the load by switching on and off based on the PWM signals generated by the SG3525. This switching action allows the inverter to convert DC power into AC power with the desired frequency and voltage level.

MOSFETs offer low ON-state resistance ($R_{DS(on)}$), resulting in minimal conduction losses and high efficiency during operation.[2]

MOSFETs have fast switching speeds, enabling them to transition between ON and OFF states quickly. This fast-switching capability is essential for achieving high-frequency operation and maintaining precise control over the output waveform, contributing to lower harmonic distortion.

MOSFETs can be easily driven by the output signals of the SG3525 PWM controller through the 4N35 optocoupler. The optocoupler provides galvanic isolation between the control and power circuits, ensuring safe and reliable operation while allowing for precise control over the MOSFET switching.

5. Step Up Transformer

The primary function of the step-up transformer is to convert the low-voltage DC input from the inverter's power source (typically a battery or DC power supply) into a higher-voltage AC output.

The transformer provides electrical isolation between the input and output circuits of the inverter. This isolation protects sensitive electronic components and ensures safety by preventing direct electrical connection between the DC input and AC output circuits.

The transformer helps in matching the impedance between the inverter circuitry and the load. Proper impedance matching improves the efficiency of power transfer and reduces losses in the system.

6. Snubber Circuit

Snubber circuits help reduce switching losses in the power devices by providing a path for the energy stored in parasitic capacitances and inductances during switching transitions. This prevents rapid

voltage and current spikes that can occur across the switch, reducing stress on the device and minimizing power dissipation.

During switching, the rapid changes in voltage and current can lead to voltage spikes across the switch. These spikes can exceed the device's voltage rating and cause damage or degrade performance. The snubber circuit absorbs and dissipates this energy, suppressing voltage spikes and protecting the switch.[7]

Uncontrolled switching transitions can generate electromagnetic interference (EMI), which can interfere with the operation of other electronic devices and circuits. By damping the switching transitions, snubber circuits help reduce EMI emissions, ensuring compliance with electromagnetic compatibility (EMC) regulations.

Snubber circuits help improve the reliability and lifespan of the power switching devices by reducing stress during switching transitions. By minimizing voltage and current spikes, they mitigate the risk of device failure due to overvoltage or overcurrent conditions.

III. HARDWARE IMPLEMENTATION [8][9][10] AND RESULTS



Fig.4. THL Circuit Hardware Implementation

In our project, the SG3525 plays a crucial role in generating the PWM signals necessary for controlling the switching of the power transistors in the inverter circuit. The SG3525 is a voltage-mode PWM controller that operates from a single power supply over a wide

range of voltages. It provides all the necessary functions for a basic PWM control circuit, including a precision voltage reference, error amplifier, oscillator, PWM comparator, and output drivers. [5][6]

The operation of the SG3525 begins with the generation of a triangular waveform by the oscillator circuit. The frequency of the triangular waveform is determined by the timing resistor (R_t) and timing capacitor (C_t) connected externally to the IC. The triangular waveform is compared with the error signal generated by the error amplifier. The error signal is derived by comparing the output voltage of the inverter circuit with a stable reference voltage provided internally. The output of the PWM comparator is a series of pulses whose width varies based on the magnitude and polarity of the error signal. These pulses constitute the PWM signals that control the switching of the power transistors in the inverter circuit. By adjusting the timing resistor (R_t) and timing capacitor (C_t), the frequency of the PWM signals can be controlled. Additionally, the duty cycle of the PWM signals, which determines the on/off ratio of the power transistors, can be adjusted by varying the amplitude of the error signal.

The SG3525 operates in a closed-loop control system where the output voltage of the inverter circuit is continuously monitored and compared with the reference voltage. Any deviation from the reference voltage results in an error signal that is fed back to the PWM comparator to adjust the duty cycle of the PWM signals. This closed-loop control mechanism ensures that the output voltage of the inverter remains stable and regulated under varying load conditions and input voltages.

The SG3525 includes built-in protections and features to enhance the reliability and safety of the inverter circuit. These protections may include overcurrent protection, overvoltage protection, undervoltage lockout, and thermal shutdown.

Additionally, the SG3525 may offer features such as soft-start and dead-time control to prevent shoot-through currents and improve efficiency in high-frequency switching applications.

In our project, the SG3525 serves as the central control unit for generating the PWM signals that drive the power transistors in the inverter circuit. By adjusting the timing resistor, timing capacitor, and feedback network, the SG3525 allows for precise control of the output voltage and frequency of the inverter. The PWM signals generated by the SG3525 determine the on/off states of the power transistors, which in turn control

the output waveform of the inverter. By modulating the width of the PWM pulses, the SG3525 regulates the amplitude of the output voltage and adjusts the frequency of the inverter output. Through its closed-loop control mechanism, the SG3525 ensures that the output voltage of the inverter remains stable and free from distortion, even under varying load conditions and input voltages.

The primary objective of the project was to reduce the third harmonic distortion in the output waveform of the inverter. Through careful design and implementation, the project successfully achieved a significant reduction in harmonic distortion compared to conventional inverters.

The inverter system demonstrated stable output voltage characteristics under varying load conditions, input voltages, and temperature variations. The closed-loop control system, implemented using the SG3525 PWM controller and feedback mechanisms, ensured precise regulation of the output voltage.

The efficiency of the inverter system was evaluated through experimental testing and analysis. By minimizing switching losses, optimizing component selection, and implementing efficient control algorithms, the project achieved improved overall efficiency compared to standard inverter designs.

The Fourier Series of the waveform obtained in the results is:

$$v_o(t) = \frac{4V_m}{\pi} (1 + \cos n\pi/3) \sin n\omega t$$



Fig.5. Experimental Outcomes

IV. CONCLUSION

The implementation of a third harmonic reduction technique using an SG3525 PWM controller and a 4N35 Optocoupler successfully mitigates third harmonic distortion in the output waveform of the inverter. By injecting a high-frequency voltage component into the reference voltage of the PWM controller, the system effectively cancels out the third harmonic component, resulting in a cleaner output waveform with reduced harmonic distortion. This approach improves the performance and efficiency of the inverter, making it more suitable for applications where low harmonic distortion is essential.

Additionally, the isolation provided by the optocoupler ensures the safety and reliability of the system. Overall, the third harmonic less inverter utilizing the SG3525 PWM controller and 4N35 optocoupler offers a practical solution for achieving high-quality output waveforms in various power electronics applications.

REFERENCES

- [1] R. Syahputra *et al.*, "Design of a single-phase power inverter with Voltage Controller using IC SG3525," *The 2nd International Conference of Science And Information Technology In Smart Administration (ICSINTESA 2021)*, 2022. doi:10.1063/5.0105933
- [2] MOSFET – power, n-channel, logic level, DPAK/IPAK 20 ..., <https://www.onsemi.com/pdf/datasheet/ntd20n06l-d.pdf> (accessed Apr. 12, 2024).
- [3] 4N35 - 6-pin general purpose phototransistor optocouplers, <https://www.onsemi.com/download/data-sheet/pdf/4n35-d.pdf> (accessed Apr. 12, 2024).
- [4] Using the SG3525 PWM Controller - Explanation and Example: Circuit Diagram/ Schematic of Push-Pull Converter, <https://tahmidmc.blogspot.com/2013/01/using-sg3525-pwm-controller-explanation.html?m=1> (accessed Apr. 12, 2024).
- [5] SG3525A SG3527A pulse width modulator control circuits, <https://www.mpja.com/download/sg3525a-datasheet.pdf> (accessed Apr. 12, 2024).
- [6] SG3525A - pulse width modulator control circuit, <https://www.onsemi.com/pdf/datasheet/sg3525a-d.pdf> (accessed Apr. 12, 2024).
- [7] A. Garcia-Caraveo, A. Soto, R. Gonzalez, and P. Banuelos-Sanchez, "Brief review on Snubber Circuits," *2010 20th International Conference on Electronics Communications and Computers (CONIELECOMP)*, Feb. 2010. doi:10.1109/conielecomp.2010.5440754
- [8] G. S. Rathore, J. Rahul, J. Singh, R. K. Pachar, and D. Birla, "An attempt to design and analysis of multilevel converter topology for renewable energy applications," *2022 IEEE 10th Power India International Conference (PIICON)*, Nov. 2022. doi:10.1109/piicon56320.2022.10045087
- [9] A. Abbas Elserougi, A. S. Abdel-Khalik, A. Massoud, and S. Ahmed, "Studying the effect of over-modulation on the output voltage of three-phase single-stage grid-connected boost inverter," *Alexandria Engineering Journal*, vol. 52, no. 3, pp. 347–358, Sep. 2013. doi:10.1016/j.aej.2013.05.006
- [10] Y. Guo *et al.*, "Third-order current harmonic suppression and neutral-point voltage balance control strategy for single-phase Three-level NPC inverter," *Energy Reports*, vol. 8, pp. 330–339, Nov. 2022. doi:10.1016/j.egyr.2022.08.157
- [11] F. Mihalic, M. Milanovic, and A. Hren, "Third harmonic elimination by SPWM for filter reduction in a over-modulated single-phase inverter," *2017 19th International Conference on Electrical Drives and Power Electronics (EDPE)*, Oct. 2017. doi:10.1109/edpe.2017.8123253
- [12] Pushendra Kachawatia, Ranjan Jhahhariya, Vishnu Sharama Sanjay Sepat, and Jitendra Singh, "Total Harmonic Distortion Analysis of Three Phase Three Level Inverter using Flying Capacitor Topology", *International Journal of Scientific Research in Engineering and Management (IJSREM)*, ISSN: 2582-3930, 5(6), pp. 1-5, June, 2021.
- [13] D.-G. Lee and R.-Y. Kim, "Control of hybrid active power filter to reduce harmonics of 3-phase Cap-less inverter," *Journal of Electrical Engineering & Technology*, vol. 18, no. 1, pp. 261–270, Sep. 2022. doi:10.1007/s42835-022-01228-7
- [14] D. Venkatramanan, V. Nimesh, B. Johnson, and S. Dhople, "Quantitative analysis of third-harmonic neutral-point current, its impacts, and mitigation in three-level NPC inverters," *2021 IEEE Energy Conversion Congress and Exposition (ECCE)*, Oct. 2021. doi:10.1109/ecce47101.2021.9595022