

Automatic Indoor Air Quality Detection and Ventilation Management System

¹Adapa Harendra Durga Prasad, ²Bandaru Venkata Sai, ³Atla Jathin Durga Bhavani Shankar, ⁴Gandikota Hari, ⁵Devana Goparaju, ⁶P. Kumar

^{1,2,3,4,5}U. G Student, Dept ELECTRONICS AND COMMUNICATION ENGINEERING,
St. Ann's College of Engineering and Technology, (Autonomous)Chirala, Bapatla Dist,
Andhra Pradesh – 523187, India

⁶Assistant Professor, Dept ELECTRONICS AND COMMUNICATION ENGINEERING,
St. Ann's College of Engineering and Technology (Autonomous), Chirala, Bapatla Dist,
Andhra Pradesh – 523187, India

Abstract—People have more and more expectations for thermal comforts, such as indoor temperature, humidity, and wind speed, as technology advances, and they pay greater attention to air quality. Poor indoor air quality affects the elderly, children, and people with respiratory allergies. This system is an indoor air quality monitoring system based on the Internet of Things smart home architecture, designed to investigate how people can live in a healthy atmosphere. The carbon dioxide index and the American Society of Heating, Refrigerating, and Air-Conditioning Engineers (ASHRAE) air quality index were chosen as the best indicators for this investigation (AQIs). The two indexes' common points are combined, and in-house environmental characteristics are analysed using Environmental Protection Administration data, with control variables imitated and their impact on air quality analysed. This project created a fuzzy rule base for environmental variable simulation and devised effective load management utilising a fuzzy controller. In the past, threshold control of indoor air quality was used, and a comfortable air quality monitoring system was built using decision logic.

Index Terms—Fuzzy control, Air Quality Index (AQI), Smart home, Internet of Things (IoT), Air quality,

I. INTRODUCTION

As a result of technological breakthroughs, our living environment has deteriorated, and many issues such as air pollution, smog, PM_{2.5} (particulate matter with a diameter of 2.5 μm or less) have steadily gained popularity. Many newborns have had lung difficulties as a result of poor air quality, and many smog-themed disaster films have been made, they appear to be a reflection of the world's troubles. Smog has three different effects:

- Smog's effects on the human body: Because a major portion of the respiratory system is frequently in touch with nature, smog has a very high concentration effect on the respiratory system. Every day, hundreds of spacecraft particles enter the respiratory tract, adhering to various parts of the lungs and being absorbed by the human body in large numbers. According to Harvard University, every 10μg/m³ increase in PM_{2.5} pollution increases patient mortality by 10% to 27%.
- Accidents on trains, highways, and sea transportation,

as well as air traffic, can occur as a result of smog, disturbing traffic flow, disrupting people's schedules, and generating disruption.

- Effects of smog on the economy: Smog not only has an effect on the respiratory system and intelligence, but it also reduces the efficiency of solar energy generation, which is already reduced by rain, fog, and smog. As a result, some academics believe that solar energy generation will decline year after year as air pollution becomes a main source of illness.

A public air quality monitoring network is used by the Taiwanese Environmental Protection Administration; however, these figures only reflect a large-scale area, and there is no way of knowing what is going on in people's homes. The most closely resembles people's living conditions is indoor air quality. This study is mostly concerned with air quality. Higher index values, higher categories, and darker display colours suggest that higher amounts of pollution are more hazardous to human health, particularly the respiratory system.

However, no hourly concentration guidelines exist for the most polluting particles, and air quality is only evaluated in 24-hour average values. Because changes in air quality can be delayed, the EPA revealed the concentration data of a "real-time air quality index," which primarily analyses major pollutants, fine particulate matters, and particle matters, allowing people to know their true feelings. When air quality is being checked, it makes more logical to monitor real-time concentration data.

Environmental challenges such as pollution and resource exhaustion have recently become major social issues. Environmental health concerns include air pollution, climatic pollution, water contamination, climate change, ozone exhaustion, and hazardous, chemical, and hazardous waste management. The quality of the environment inside is the most essential component because individuals spend 9 percent of their time indoors. The quality of indoor air, thermal comfort, visual, lighting, and acoustic comforts are the environmental



factors that influence the indoor environment (EIQ).

air quality (IAQ) is concerned with air pollutants that are harmful to humans, whereas thermal comfort quality is concerned with air pollutants that can affect people's comfort in a room. Many health problems have been linked to various types of air pollution, such as CO, CO₂, NO₂, particle matter, VOC, temperature, and humidity, over the last two decades. It would affect human health by causing dizziness, tiredness, respiratory and cardiovascular diseases, and even cancer, and air pollution causes 4.3 million deaths globally each year.

For identifying and decreasing contaminants in a space, indoor air quality monitoring and control are essential. CO, CO₂, NO₂, PM, temperature, and humidity are all detected in real time by indoor air quality sensors such as the MQ-135, MQ-7, MQ-9, and DHT11, providing for greater health. Using a chimney, ventilation, exhaust fan, and water sprinkler, the ventilation system is utilised as a supporting system to maximise the air quality system's ability to manage and mitigate pollutants. The Indoor Air Quality Index is calculated by comparing human tolerable limits to a set of ranges (IAQI). The IAQI is defined as the sum pollutants concentration ratio of toxicity level tests and is used to quantify the impact of polluted air on people's overall health. Meanwhile, Internet of Things (IoT) technology can be utilised to improve the system's performance and make it easier for users to monitor and operate it remotely. In dealing with some of the most complicated difficulties, an integrated smart system will produce a sensitive, effective, and faster reaction output than a traditional system.

Recent work has been done for assessing Indoor Air Quality (IAQ) combining fuzzy logic and reasoning approaches, providing distinct answers for different types of air contaminants. By combining some air pollution factors such as PM, PM₁₀, CO, NO₂, NOP (number of passengers), and temperature, the fuzzy logic controller is utilised to estimate comfort and air quality index. This index is also used to notify people about the allowable air quality for various pollutant toxicity levels. In addition, based on numerous toxicity levels of air pollutants, the fuzzy logic controller determines the output action reaction in the form of an on/off exhaust fan, hot water valve, fresh air dumper, air conditioner, and DC motor control speed. As a control system, thermal comfort pollutants generate a simulation of fuzzy logic interior environment quality that interacts with lighting and windows (temperature and humidity). By focusing on indoor air contaminants, fuzzy logic-based indoor environmental quality (IEQ) can help to improve the building's condition. Those works provide a good answer for evaluating the environment of interior air pollutants; however, the primary flaw is the lack of a reasoning method for calculating the value of the index that can distinguish indoor air pollutants and thermal comfort pollutants. Furthermore, employing only a few types of air pollutants as environmental air quality criteria, whereas air quality is controlled by many parameters of air pollutants with varying features and human health effects.

The environment indoor air quality index (EIAQI), which includes four indoor air pollutants (IAP) and four thermal comfort pollutants, is the system's main reference index

status level (TCP). The fuzzy logic controller's IAQI and TCI values are divided using the clustering technique. Because the two indices have various properties and human health impacts in each type of pollution, this classification is used. The reasoning process will be used to detect, classify, analyse, and provide advice on IAP and TCP utilising a fuzzy inference system (FIS). This system has a control output that includes an inlet exhaust, exit exhaust, fan, buzzer, and LED, all of which operate automatically based on the EIAQI value. The author's contribution is the development of an EIAQI system that employs a fuzzy logic controller to generate the EIAQI as a quality indicator, which can identify indoor air and thermal comfort pollutants separately because they have different features and human health implications.

The purpose of this research is to explore how individuals construct an index system in the home environment, based on smart home and Internet of Things system architecture. The AQI is presently the world's most widely used index, and it focuses on six gases: Some of the gases found in the atmosphere include ozone (O₃), fine particulate matter (FPM), particle matter (PM), carbon monoxide (CO), sulphur dioxide (SO₂), and nitrogen dioxide (NO₂) (NO₂). This project investigates fine particulate matter, carbon monoxide (CO), and carbon dioxide (CO₂), all of which are typically present in homes. MATLAB simulation was used to investigate the indoor environment, fuzzy control was applied to data of fine particulate matter and CO₂ in the indoor environment, and a logic basis based on AQI data was constructed for enhanced air quality in homes. This project uses two sets of equipment with fine particulate matter sensor modules to conduct on-site measurements of indoor environment data, CO, and CO₂. The three modules gathered the data from the Arduino Uno board for integration and then transferred it to the computer terminals via the ESP8266 Wi-Fi module for additional calculation and analysis.

To reduce fine particulate matter and CO₂ levels, this system uses fuzzy control and AQI estimation to determine when to open the air purifier, window, and ventilation unit. The system's CO concentration threshold was determined by the AQI, and users were alerted via automated warnings and buzzers. [?]

II. RELATED WORKS

Peter T. Lewis initially discussed the Internet of Things (IoT) in a speech in 1985, and the Massachusetts Institute of Technology (MIT) combined RFID with the network in 1999 to achieve intelligent planning and management. Following that, at the World Summit on the Information Society (WSIS), the International Telecommunication Union (ITU) proposed the notion of the Internet of Things (IoT), which popularised the phrase [2]. IoT refers to combining data collected by sensors from electronic tags or RFID devices that aren't connected to the Internet to collect various data, such as temperature, brightness, and air quality sensors, so that sensors can record environmental changes and users can search for the

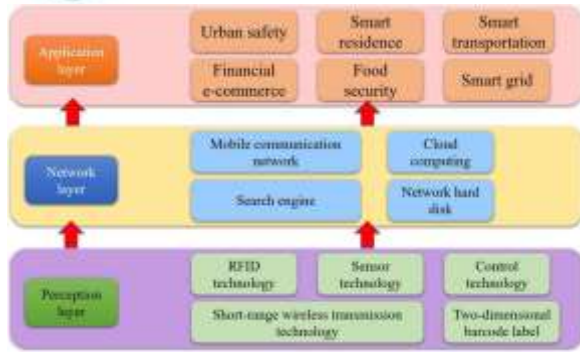

Fig. 1. Architecture [19]

information they need through wireless networks like Wi-Fi, ZigBee, BlueTooth, and LoRa, or through wired networks. There are numerous major IoT technologies, each with its own set of communications protocols, such as NB-IOT, LoRa, and SIGFOX. Different IoT devices employ different network nodes, such as IPv4 and IPv6. According to different work projects, the 3-layer IoT architecture defined by the European Based on the above concept, the Telecommunications Standards Institute (ETSI) is made up of an application layer, an internet layer, and a sensing layer. The architecture is depicted in Figure 1:

III. DESIGN & METHODOLOGY

The system architecture for this study is based on IoT smart home concepts and is separated into four primary elements, as illustrated in Fig 3.1: Part 1: environmental sensing, Part 2: wireless transmission, Part 3: analysis, and Part 4: load control. As shown in Figs 3.2, the nodes of two environmental sensors, including an indoor sensing device, are set up for environmental sensing. Three sensors for fine particulate matter, In the indoor nodes, sensors for CO₂, CO, and an infrared emitter were mounted; the sensors retrieved data from the control panel for further processing. The infrared emitter is located in the laboratory's tiny room and is used to regulate the ventilation unit and air purifier; A fine particulate matter sensor near to a window serves as the outside node [5-7].

The loads under control were the window, air purifier, and ventilation unit. The Arduino Uno board will activate the ventilation unit and air purifier through the infrared emitter when CO₂ or fine particle matters surpass the norm [8-10]. The Arduino Uno board will activate the ventilation unit and air purifier using the infrared emitter when CO₂ or fine particle matters surpass the standard, lowering the concentration. The indoor node flow chart, as illustrated in Fig 3.3, is one aspect of the software architecture.

The three sensors are installed indoors and send data to the Arduino Uno board at regular intervals. They communicate with one another using an ESP8266 Wi-Fi module. The indoor nodes, for example, have an infrared emission module and a buzzer, which could receive computer analysis results to determine whether to turn on the air purifier,

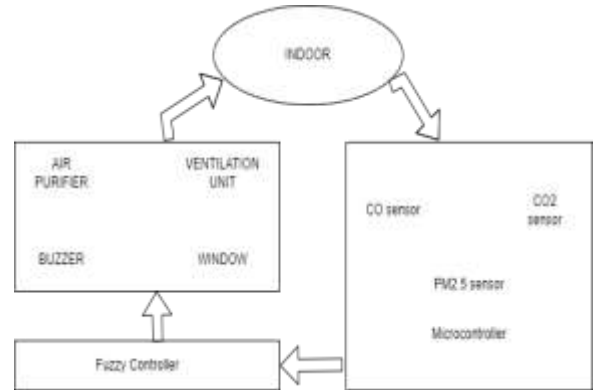

Fig. 2. System architecture. The system architecture for this project is built on IoT smart home concepts and is separated into four primary parts: Environmental sensing is part one, wireless transmission is part two, analysis is part three, and load control is part four.

Particle size (µm)	Name	Description
< 2.5	Fine particulate matters (PM2.5)	Entering the bloodstream directly through alveoli
2.5-10	Coarse particulate matters (PM2.5-10)	Being inhaled by the human respiratory system
< 10	10 µm particulate matters (PM10)	Through the nasal cavity to the throat
< 100	Total suspended particulates (TSP)	Beach sand being suspended in the air

Fig. 3. Classification of energy harvesting sources

ventilation unit, or load strength setting, as well as whether the buzzer is emitting warning sounds to remind users to be environmentally conscious [9-10]. As can be seen in Fig. The Arduino Uno module, version 3.4, is the foundation of the complete system for indoor air monitoring.

An ATmega328 microcontroller with an integrated analog-to-digital converter (ADC) and 14 digital input/output pins numbered 0 to 13, including 6 PWM control pins, 1 UART control wire, 1 I2C SCL/SDA line, and 6 analogue input/output pins, powers the Arduino Uno board. Table 3.1 shows the precise characteristics, which are supplied via a transformer or USB. The study's main component was an Arduino Uno board with an ESP8266 ESP01 module, an infrared receiver, an infrared emitter, and various gas sensors[14].

Index level	Category	PM2.5 concentration (µg/m ³)	People's life
1	Low	0-11	May go out as usual
2	Low	12-23	
3	Low	24-35	
4	Medium	36-41	Go out less if there are symptoms, such as sore eyes and throat
5	Medium	42-47	
6	Medium	48-53	
7	High	54-58	
8	High	59-64	Try not to go out
9	High	65-70	
10	Very high	> 70	

Fig. 4. Effects on the AQI are compared.

Parameters	Indoor Air Quality Standards			
	NBC 2018	ASHRAE	WHO	OSHA
CO	20 mg/m ³	9 ppm (8 hours)	30 mg/m ³	50 ppm (8 hours)
CO ₂	-	800 ppm	-	5000 ppm
PM ₁₀	60 µg/m ³	-	-	-
PM _{2.5}	-	-	50 µg/m ³	5 mg/m ³
SO ₂	80 µg/m ³	-	20 µg/m ³	5 ppm (8 hours)
NO _x	20 µg/m ³	-	-	-
NO ₂	-	-	40 µg/m ³ (Annual)	5 ppm (8 hours)
HC	800 µg/m ³	-	-	-

Fig. 5. Indoor Air Quality Standards

A. Sensor module for CO₂

As shown in Fig. 3.6, the CO₂ sensor module in this study is the NDIR infrared sensor module (MH-Z14A), which predominantly measures CO₂ in indoor air using the non-distributed infrared ray theory. Internal temperature correction, digital and analogue output, and a measuring range of 0-5000 ppm, as well as a long service life, are all features of this sensor. Table 3.2 contains the exact specifications.

B. Sensor module for fine particulate particles

The GP2Y1010AU0F model, which is displayed in Fig 3.7, was built by SHARP to quantify fine particulate matter (PM_{2.5}) concentrations. It mostly measures dirt, dust, and tiny particulate materials indoors, with a range of 0-520 micro gram/m³. The actual working circuit for this sensor is shown in Fig 3.8, and it uses an LED light source to detect particulate matter in the air.



Fig. 6. Fine particulate matter sensor module (GP2Y1010AU0F). SHARP created the sensor used to measure the fine particulate matter (PM_{2.5}) concentration in this investigation, namely, the GP2Y1010AU0F model

C. Block Diagram

To comply with standards of indoor air quality (IAQ) and thermal comfort, the interior air quality is monitored and controlled using a fuzzy controller. Carbon dioxide (CO₂) and carbon monoxide (CO) are used as input signals (CO), and particulate matter (PM) concentrations are the basic four constituents of IAQ (PM 2.5). The output signals are the EIAQ

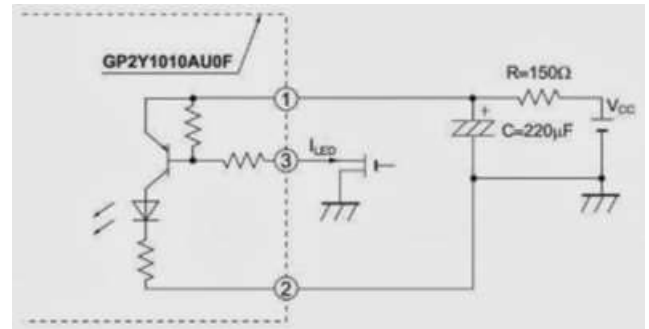

Fig. 7. Fine particulate matter sensor module circuit (GP2Y1010AU0F). Using an LED light source, this sensor detects particulate matter in the air, and the actual operational circuit

values, which are classified into four categories: excellent, decent, horrible, and worse. Figure 3.11 shows the output control signals that can be used to drive the fan control relay, outlet and inlet exhaust control relays, to turn the power on and off, there is a buzzer and an LED control.

The input signals are collected by the three sensors, which are then sent to the microcontroller and converted from analogue to digital data. Indoor air quality index fuzzy logic is separated into four clusters in the function of the environment, with cluster index 1 (IAQI 1) containing CO and CO₂, and cluster index 2 (IAQI 2) containing PM 2.5. Following the collection of data from sensors, the first step is to double-check all input values before proceeding to the fuzzy logic block. The prepared input fuzzy sets are used to fuzzify digitised input data. The fuzzy rule will then infer the fuzzified data, which will subsequently be defuzzified to yield IAQI 1, IAQI 2 values. Finally, the four cluster index values will be added to the EIAQI value. Depending on the EIAQI result, the output system will be turned on or off. The EIAQI system's functioning principle is represented in Figure 3.3.

D. Fuzzy control

Because standard PID or constant control is difficult to provide precise air quality control, the nonlinear multi-input multi-output (MIMO) mathematical model is required. which is formed by the interaction between the input parameters and the output loads, to use AQI and ASHRAE's CO₂ index as load control standards. As a result, in this project, the fuzzy theory was employed to control the load in order to achieve the highest air quality prescribed by international standards: 0_iAQI_i50, 0_iCO_i2 concentration_i400.

E. Load control

The air purifier, ventilation unit, and buzzer are the three main loads for control in this project.

IV. RESULT AND ANALYSIS

Here explains the results that are gathered. The values measured by the sensors are shown using a thingspeak graphical

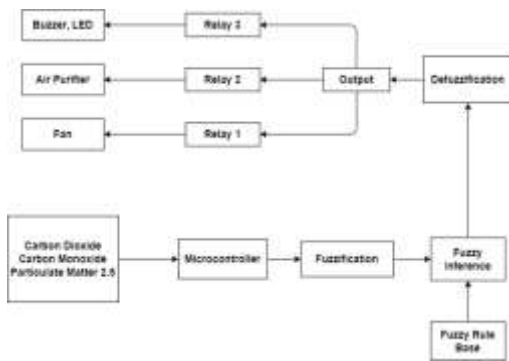

Fig. 8. Block Diagram of indoor air quality monitoring system

human-machine interface in this project, which used Wi-Fi wireless transmission technology to transmit environmental data to the computer.

A. Interfacing of sensor

The sensors are interfaced with the microcontroller. It includes carbon dioxide (CO₂) sensor, carbon monoxide (CO) sensor and fine particle sensor (PM_{2.5}).

This project first evaluated the indoor air pollutant evaluation method, then chose the appropriate AQI evaluation method based on fine particulate matters, CO, and CO₂ in the AQI, and then compared the CO₂ evaluation standard proposed by ASHRAE to the CO and fine particulate matters proposed by the AQI. Working with the ASHRAE-recommended CO₂ evaluation standard, CO, fine particulate matters, O₃, particle matters, SO₂, and NO₂ are generally referred to by AQI in this study. The impacts of the two independent indices on indoor air quality are explored as the experimental basis for subsequent load adjustment in order to achieve the best environment, using PROTEUS to simulate indoor CO and fine particulate matters. PROTEUS can also be used to model the impacts of fine particles. Figures 4.1 and 4.2 demonstrate the impact of CO in the environment on air quality subindices, respectively.

According to modelling data, fine particulate matter and CO are nonlinearly connected to AQI levels. If one of the indices is abnormally high, the current AQI will be set to the highest value of all values, resulting in an AQI that is unacceptable. For the greatest indoor air quality, the AQI must be less than 50 and the CO₂ index must be less than 450 ppm, according to the ASHRAE CO₂ index. Because the majority of fine particulate matter indoors comes from outside, closing windows reduces the concentration of fine particulate matter indoors. However, closing windows for an extended period of time will raise CO₂ levels, necessitating the opening of windows or the use of ventilation systems for ventilation. As a result, the main assessment method of fuzzy logic is how to cope with indoor and outdoor air quality.

A graphical representation of CO sensor output over time is shown in Figures 4.3 and 4.4. Figures 4.5 and 4.6 depict the work progress and simulation output.



Fig. 9. CO sensor outputs



Fig. 10. CO sensor outputs

B. System implementation and application

The numbers measured by the sensors will be displayed using a C graphical human-machine interface, and the system will use Wi-Fi wireless transmission technology to provide environmental data to the computer. In addition, the information was saved in a Microsoft Excel database for historical data testing, analysis, and research. After entering the online system, users will see a reminder that the system is live.

V. CONCLUSION

The proposed system is an IoT smart home architecture-based design and implementation of an indoor air quality control system. The Raspberry Pi board and numerous sensors were employed as the hardware's core, and Excel was used for the software's terminal processing. The data of the indoor environment is assessed based on the experimental results, and the load is regulated by integrating fuzzy logic principles. This project's goal is to improve living quality in all residences and maintain good indoor air quality so that children and people with allergies are less likely to develop

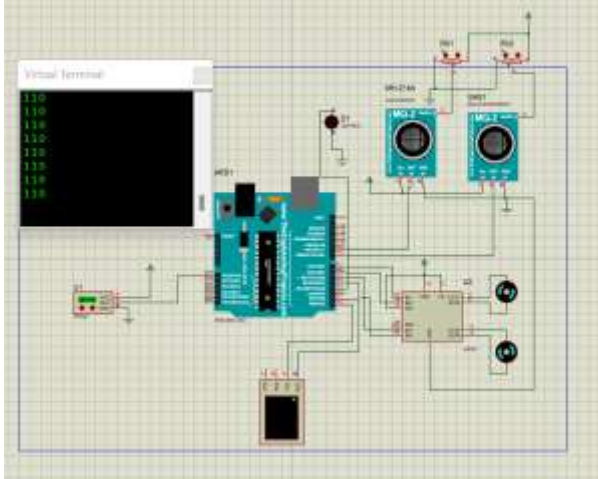

Fig. 11. Simulation Result



Fig. 13. Interfacing of sensors with microcontroller

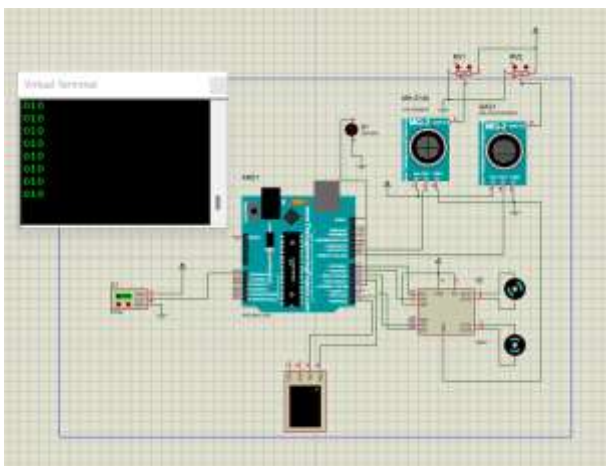

Fig. 12. Simulation Result



Fig. 14. Interfacing of sensors with microcontroller

asthma or respiratory problems as a result of poor air quality, and people are less likely to lose productivity and sleep as a result of high CO₂ concentrations, resulting in good air quality environments for the general public. Indoor air quality is measured using the AQI and the CO₂ concentration index published by ASHRAE, and indoor fine particle matters, The common relationship between the two indices is used to define outdoor particle matter, CO, and CO₂ standards. Scholars believe that the optimal air quality is between 0 and 50 AQI, and that in the CO₂ concentration table created by ASHRAE, the CO₂ content should be between 0 (ppm) and 450 (ppm). PROTEUS will be used in the coming days to investigate the controllable environmental parameters that might be used as the fuzzy rule base. Because outside air quality has the greatest impact on indoor air quality, if the door and window are opened for a short period of time under any management, the indoor air quality improves, but if the door and window are closed for a long period of time, the CO₂ concentration rises. As a result, the goal of this project is to use data integration to respond quickly to increased pollution levels and poor air quality, in order to prevent individuals from developing

physical and mental illnesses as a result of spending too much time in a hazardous environment. For this project, the data from no control, continuous control, and fuzzy control was kept in Excel to improve the reliability of the fuzzy control mode and to conduct further analysis and improvement of the data in the coming days.

The goal of this study is to learn more about fine particulate matter, CO, and CO₂. Because human dander and pet hair damage the air, and some volatile compounds can also cause temporary poor air quality, many families now have dogs, which they intend to add to the fuzzy inference in the future. Indoor environmental quality measures may become more precise as a result of the integration of these aspects, and more appropriate methods to eradicate allergies and physical discomforts may be implemented.

REFERENCES

- [1] J. Huang, N. Duan, P. Ji, C. Ma, A crowdsourcing-based sensing system for monitoring fine-grained air quality in urban environments. *IEEE Internet Things J.* 6(2), 3240-3247 (2019)
- [2] S. Dhingra, R.B. Madda, A.H. Gandomi, R. Patan, M. Daneshmand, Internet of Things mobile-air pollution monitoring system (IoT-Mobair). *IEEE Internet Things J.* 6(3), 5577-5584 (2019)
- [3] D. Zhang, S.S. Woo, Real time localized air quality monitoring and prediction through mobile and fixed IOT sensing network. *IEEE Access* 8, 89584-89594 (2020)
- [4] McGrath S, Flanagan C, Zeng L, O'Leary C. IoT personal air quality monitor. In: 2020 31st Irish signals and systems conference (ISSC), 2020.
- [5] K. Zheng, S. Zhao, Z. Yang, X. Xiong, W. Xiang, Design and implementation of LPWA-based air quality monitoring system. *IEEE Access* 4, 3238-3245 (2016)
- [6] Kumar A, Kumari M, Gupta H. Design and analysis of IoT based air quality monitoring system. In: 2020 International conference on power electronics and IoT applications in renewable energy and its control (PARC), 2020.
- [7] M.P. Ha, S. Metia, M.D. Phung, Sensing data fusion for enhanced indoor air quality monitoring. *IEEE Sens J* 20(8), 4430-4441 (2020)
- [8] Jha RK. Air quality sensing and reporting system using IoT. In: 2020 Second international conference on inventive research in computing applications (ICIRCA), 2020.
- [9] L. Zhao, Wu. Wenyang, S. Li, Design and implementation of an IoT-based indoor air quality detector with multiple communication interfaces. *IEEE Internet Things J.* 6(6), 9621-9632 (2019)
- [10] Moharana BK, Anand P, Kumar S, Kodali P. Development of an IoT-based real-time air quality monitoring device. In: 2020 International conference on communication and signal processing (ICCSP), 2020.
- [11] Babburi, S. Lightweight Distributed Provenance Framework for Edge and IoT Data Systems.
- [12] 20. Gaddam, S. From Fixed Specifications to Self-Adapting Systems: A Machine Learning Perspective on Software Engineering.
- [13] 21. Immadi, S. K. (2025). Optimizing ERP for Human Capital Management. *Applied Research for Growth, Innovation and Sustainable Impact*, 377–384. <https://doi.org/10.1201/9781003684657-63>
- [14] 22. Reddy, S. K. R. Developing a Modular AI Framework to Enhance Scalability and Personalization in Next-Generation Reward Platforms.
- [15] 23. Poojari, R. Frameworks for Data Management and Lineage in Large-Scale Healthcare Data Systems.
- [16] 24. Mahimalur, R. K., Vagham, M., & Manoharan, D. Devops Lifecycle Management And Cloud Migration Assessments: A Security-Driven CICD Perspective.
- [17] 25. Viswanathan, V. Generative AI for Smarter Workforce Planning and Enterprise Resource Decisions.
- [18] 26. Gajula, S. (2026, March). Two Pillars of Banking Intelligence: A Comparative Analysis of AI Techniques for Fraud Prevention and Churn Mitigation. In 2026 14th International Symposium on Digital Forensics and Security (ISDFS) (pp. 1-6). IEEE.
- [19] 27. Maturi, S. Y. (2023). Crowdsourced frontier: Unveiling autonomous adversarial cybercapabilities via open AI competition. *International Journal of Intelligent Systems and Applications in Engineering*, 11(1s), 275–284.
- [20] 28. Venkata Ramana, P. (2024). AI-driven predictive analytics in ERP systems for proactive supply chain optimization. *International Journal of Research in Information Technology and Computing*, 8(4).
- [21] 29. Srikanth Kavuri. (2025). AI-DRIVEN TEST AUTOMATION FRAMEWORKS: ENHANCING EFFICIENCY AND ACCURACY IN SOFTWARE QUALITY ASSURANCE. *International Journal of Applied Mathematics*, 38(10s), 699–710. <https://doi.org/10.12732/ijam.v38i10s.990>
- [22] 30. Venkata Pavan Kumar Gummadi. (2026). Infrastructure Optimization Techniques for Enterprise Integration Platforms: A Comprehensive Analysis. *Computer Fraud and Security*, 37–44. <https://doi.org/10.52710/cfs.875>
- [23] 31. Shashank, A. (2025). AI-Enhanced ETL Processes: Leveraging Artificial Intelligence for Optimized Data Integration Systems. *Journal Of Multidisciplinary*, 5(8), 219-225.
- [24] 32. Kandula, S. T. R., Susarla, R. S., & Boyapati, P. K. (2025, July). Enhanced Cyber Security Using Global Local Artificial Neural Network Based Intrusion Detection in Big Data Environment. In 2025 IEEE 4th World Conference on Applied Intelligence and Computing



- (AIC) (pp. 426-431). IEEE.
[25] 33. Boyapati, P. K. Building a centralized data operations hub for healthcare enterprise integration. IJSAT-Int. J. Sci. Technol. 16 (2). <https://doi.org/10.71097/IJSAT.v16.i2.3219>